

MiniTec
THE ART OF SIMPLICITY

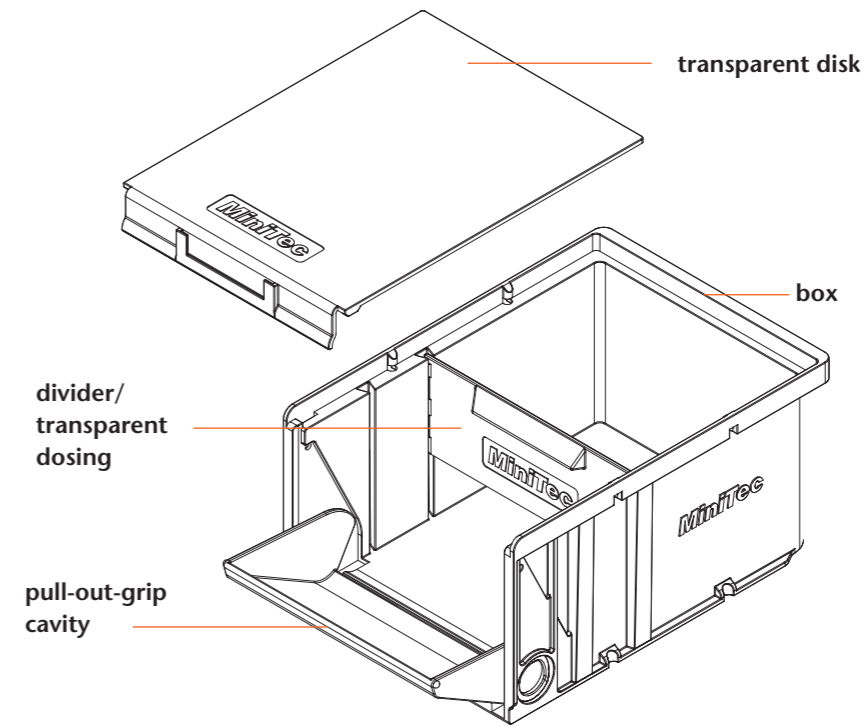

KANTAINER
FOR KANBAN-MANAGEMENT



Workplace Systems

MINITEC KANTAINER

The name “Kanban” originates from Japanese, and translates roughly as “signboard”. Kanban management is a cost-effective system to control the logistical supply chain to improve and maintain a high level of production. This method of production processing is based on the pull-principle where the demand input is given by returning the “Kanban” – in this case an empty container.

The new developed **KanTainer** provides an ideal method to implement the principles of lean-production using kanban-control. In combination with the mounting solutions and the ergonomic designed working places of MiniTec, a complete, safe and economic all-round-package for your manual production is ensured. The KanTainer is optimized for maximum stock utilisation, helping to keep the working place operational and productive.

The **KanTainer** consists of the box, the pull-out-grip cavity, the divider and the cover. The ergonomically formed hand grip cavity allows easy removal of small parts.

The divider can be used in two different positions – for simultaneous storage or allocation of complementary goods, like connectors and screws or – for one-container-kanban. If the lower part is cut off - the divider serves as a metering disc and can be dropped into several convenient positions. The transparent and adjustable disc makes it simple and easy to allot and control material replenishment – as well as checking the remaining quantities. The cover provides excellent security against accidental opening, it protects components from dirt and prevents parts mixing during transportation.

Thanks to the closed construction of the **KanTainer**, it offers 25 per cent more storage volume than usual storage boxes. Ideal when workspace is often at a premium. The boxes are labelled on front and back for easy and exact identification in stores and at the work place, an important consideration when working to avoid costly stock mistakes. The box is fitted with a rail at the back for quick and easy positioning into an ergonomic sloping position at the working station.

Up to 7 fully-loaded containers can be stacked safely using the provided holding. The KanTainer offers you all the requirements to make storing, commissioning and assembly easier and safer.

The **KanTainer** offers you a solution to simplify storage and control production demands.

With our extensive MiniTec modular profile system and compatible system components, we can solve many of your problems within manual assembly and production processes.

FEATURES

- For integrated Kanban-system: No decanting – removes potential refilling errors
- The retractable pull-out-grip cavity ensures total use of storage rack
- Easy access to parts via the ergonomic grip cavity
- Transparent cover protects against dirt and mixing of parts
- Security against accidental opening of the grip cavity or losses with cover fitted
- Easy content control
- The transparent metering disc makes it easy to check the remaining quantity
- The metering disc avoids uncontrolled trickling of small parts
- Safe stacking of KanTainer with holding pins
- Labelling on front and rear to avoid misidentification
- Holding device on back side of container
- Bottom-side guide rails for longitudinal and transverse transport



TECHNICAL DATAS

Dimensions:	175x126x88 [mm]	Colour:	Basalt Grey (RAL 7012)
Load capacity:	50 kg		[Part-No.: 32.0870/0]
Content capacity:	5 kg		or
Temperature resistance :	-20°C bis +90°C		Orange (RAL 2004)
Material:	Polypropylen, Polystyrol		[Part-No.: 32.0870/1]

MINITEC LOCATIONS

MiniTec GmbH & Co. KG (Deutschland)

MiniTec Allee 1 | 66901 Schönenberg-Kübelberg
Tel. +49 (0)6373 81270 | Fax +49 (0)6373 812720
info@minitec.de | www.minitec.de

MiniTec GmbH & Co. KG (Deutschland)

Fürther Straße 33 | 90513 Zirndorf
Tel. +49 (0)911 2789000 Fax +49 (0)911 27890099
zirndorf@minitec.de | www.minitec.de

MiniTec España S.L.U. (España)

C/ Carlos Jiménez Díaz, 7. Pol. Ind. La Garena
28806 Alcalá de Henares, Madrid
Tel. +34 91 6562652 | Fax +34 91 6775304
info@minitec.es | www.minitec.es

MiniTec S.N.C. (France)

2, rue Charles Desgranges | 57214 Sarreguemines
Tel. +33 (0)3 8727 6870 | Fax +33 (0)3 8727 6877
info@minitec.fr | www.minitec.fr

MiniTec.at GmbH (Österreich)

Beethovenstraße 12 | 2380 Perchtoldsdorf
Tel. +43 (01)865 95 59 | Fax +43 (01)865 95 5990
office@minitec.at | www.minitec.at

MiniTec Solutions România SRL (România)

Str. I.M. Pestalozzi Nr. 22 | 300115 Timis
Tel. +40 (0)722 22 9134 | Fax +40 (0)256 242 266
office@minitec.ro | www.minitec.ro

MiniTec Slovenia d.o.o. (Slovenija)

Griže 24a | 3302 Griže
Tel. +386 (0)590 71390 | Fax +386 (0)590 71399
info@minitec.si | www.minitec.si

MiniTec Slovakia s.r.o. (Slovensko)

Rabčická 332 | 02944 Rabča
Tel. +421 43 5524350 | Fax +421 43 5524352
info@minitec-slovakia.sk | www.minitec-slovakia.sk

MiniTec System Sweden (Konungariket Sverige)

Kapplöpningsgatan 14 | 2520 30 Helsingborg
Tel. +46 4214 0880 | Fax +46 4214 0860
info@minitec.se | www.minitec.se

MiniTec UK Ltd. (United Kingdom)

Unit 1A & 1B Telford Road | Houndmills Estate
Basingstoke | Hampshire. RG21 6YU
Tel. +44 (0)1256 365605 | Fax +44 (0)1256 365606
info@minitec.co.uk | www.minitec.co.uk

MiniTec Framing System LLC (United States of America)

100 Rawson Road, Suite 228 | Victor, NY 14564 USA
Tel. +1 585 9244690 | Fax +1 585 9244821
sales@minitecframing.com | www.minitecframing.com

MINITEC PRODUCT LINE

PROFILE SYSTEM



CONVEYORS



WORKPLACE SYSTEMS



MACHINE PROTECTION



TURN-KEY SOLUTIONS

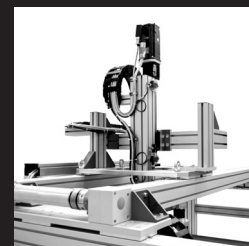

LINEAR SYSTEM

